

XR720C - XR740C - XR760C

Refrigeration controllers with HACCP
integrated features

Contents

1. GENERAL WARNING	1
2. GENERAL DESCRIPTION	1
3. FIRST INSTALLATION	1
4. HACCP FUNCTIONS	1
5. THE DISPLAY	1
6. DISPLAY	2
7. ALARM LIST- HACCP MENU	2
8. FUNCTION MENU	3
9. OTHER FUNCTIONS OF THE KEYBOARD	3
10. CONTROLLING LOADS	4
11. PARAMETER LIST	4
12. DIGITAL INPUT	5
13. INSTALLATION AND MOUNTING	5
14. ELECTRICAL CONNECTIONS	6
15. USE OF THE PROGRAMMING "HOT KEY "	6
16. ALARM SIGNALS	6
17. TECHNICAL DATA	6
18. WIRING CONNECTIONS	6
19. DEFAULT SETTING VALUES	6

1. GENERAL WARNING

1.1  PLEASE READ BEFORE USING THIS MANUAL

- This manual is part of the product and should be kept near the instrument for easy and quick reference.
- The instrument shall not be used for purposes different from those described hereunder. It cannot be used as a safety device.
- Check the application limits before proceeding.

1.2  SAFETY PRECAUTIONS

- Check the supply voltage is correct before connecting the instrument.
- Do not expose to water or moisture: use the controller only within the operating limits avoiding sudden temperature changes with high atmospheric humidity to prevent formation of condensation
- Warning: disconnect all electrical connections before any kind of maintenance.
- Fit the probe where it is not accessible by the End User. The instrument must not be opened.
- In case of failure or faulty operation send the instrument back to the distributor or to "Dixell s.r.l." (see address) with a detailed description of the fault.
- Consider the maximum current which can be applied to each relay (see Technical Data).
- Ensure that the wires for probes, loads and the power supply are separated and far enough from each other, without crossing or intertwining.
- In case of applications in industrial environments, the use of mains filters (our mod. FT1) in parallel with inductive loads could be useful.

2. GENERAL DESCRIPTION

The XR700 series has been designed to satisfy the HACCP requirements. Each instrument has the possibility to record the **last 20 alarm conditions** that could happen in the normal refrigerated applications.

Model **XR720C**, format 32 x 74 mm, is a thermostat with off cycle defrost designed for refrigeration applications at normal temperature. It provides a relay output to drive the compressor and 2 NTC probe input.

Model **XR740C**, 32x74 mm format, is a microprocessor based controller, suitable for applications on medium or low temperature refrigerating units. It is provided with two relay outputs to control compressor and defrost, which can be either electrical or reverse cycle (hot gas). It is also provided with 3 probe inputs, NTC, one for temperature control, the other, to be located onto the evaporator, to control the defrost termination temperature.

The **XR760C** model, 32x74 format, is a microprocessor based controller suitable for applications on medium or low temperature refrigerating units. It is provided with 3 relay outputs to control compressor, defrost - which can be either electrical or hot gas - the evaporator and fans. It is also provided with three NTC probe inputs, one for temperature control, one to control the defrost end temperature of the evaporator and the third, optional, for the display. There are 1 digital inputs (free contact) configurable by parameter.

By internal real time clock it is memorised when an alarm happened and it is also possible to programme up to eight daily defrost cycles, divided into holidays and workdays. A "Day and Night" function with two different set points is fitted for energy saving.

3. FIRST INSTALLATION

At the first installation it's required the following:

1. set the time
2. reset possibly black out alarm.

3.1 HOW TO SET THE CLOCK

If at power on onto the upper display the message appears "rtC" alternate with the temperature: it means that the clock has to be regulated.

How to do:



1. Press any key until on the lower display the "Hur" label appears and on the upper one the time.
2. Press the SET key: the time start flashing.
3. Adjust the time with the \downarrow and \uparrow keys.
4. Confirm the value by pressing the SET key, the following parameter will be displayed.

5. Repeat the operations 2. 3. and 4. on the other real time clock parameters:
 - **Min: minutes** (0÷60)
 - **UdA: day of the week** (Sun= Sunday, Mon= Monday, tuE = Thursday, UEd = Wednesday, tHu = Thursday, Fri = Friday, SA_t =Saturday).
 - **dAy: day of month** (0÷31)
 - **Mon: month**(1÷12)
 - **yEA: year** (00÷99)
 - **Hd1, Hd2, Hd3: days to which apply the holiday defrost.** (nu, Sun, Mon, tuE, UEd, tHu, Fri, SA_t)

3.2 HOW TO RESET THE BLACK OUT ALARM AT FIRST INSTALLATION AND EVERY TIME THE INSTRUMENT IS VOLUNTARILY TURNED OFF AND ON.



If the clock of the instrument is adjusted and the black out alarm signalling is enabled (par. **bLE=yES**), at power on the **PUSH SET** message is displayed if the temperature is higher than the high temperature value (par. **Hit** into Menu)

What to do:

1. **Push the SET key: the delay of temperature alarm at start-up** start running (par. **dAo**) and the black out alarm is not logged.

4. HACCP FUNCTIONS

4.1 THE HACCP ALARMS MANAGED

- Maximum temperature alarm
- Minimum temperature alarm
- Digital input alarm
- Black-out alarm

4.2 FOR EACH TEMPERATURE ALARM THE FOLLOWING IS RECORDED

1. Starting time (date and time)
2. End time (date and time)
3. Maximum or minimum temperature reached during the alarm phase
4. When this maximum temperature was reached (date and time)

4.3 FOR EACH DIGITAL INPUT ALARM THE FOLLOWING IS RECORDED

1. Starting time (date and time)
2. End time (date and time)

4.4 BLACK OUT ALARM

Only if the internal real time clock is still working the black out alarm is signalled. At next power on the black out alarm is given only if the temperature is higher than maximum alarm value. In this case the following is recorded:

1. Power off time (Date and time)
2. Power on time (Date and time)
3. Maximum temperature reached (Date and time)

5. THE DISPLAY

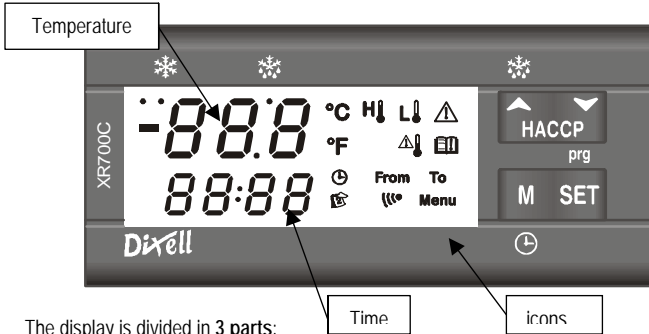

The display is divided in 3 parts:

- Upper left part: to see the temperature (upper display)
- Lower left part: to see the time (lower display)
- Right part: icons area

5.1 THE KEYBOARD

SET To display and modify target set point; in programming mode it selects a parameter or confirm an operation.

- HACCP (UP)** To enter the HACCP menu.
In programming mode: it browses the parameter codes or increases the displayed value. By holding it pressed for 3s the defrost cycle is started.
- HACCP (DOWN)** To enter the HACCP menu.
In programming mode: it browses the parameter codes or decreases the displayed value.

M To enter the "Menu".
By holding it pressed for 3s the Clock menu is entered.

KEY COMBINATIONS

- ▲ + ▼** To lock and unlock the keyboard.
- SET + ▼** To enter the programming mode.
- SET + ▲** To exit the programming mode.

5.2 SYMBOLS ON THE FRONTAL FRAME

LED	FUNCTION	MEANING
	ON	The compressor is running
	FLASHING	- Programming Phase (flashing with LED) - Anti-short cycle delay enabled
	ON	The defrost is enabled
	FLASHING	Drip time or delay time in progress

5.3 THE ICONS

Icon	Meaning
°C	Celsius degree
°F	Fahrenheit degree
H _l	High temperature alarm
L _l	Low temperature alarm
	Critical temperature (minimum or maximum minima)
	Digital input alarm
	Alarm list
	Clock
	Date
	Infrared transmission
Menu	It signals "The function menu"
From	Start time
To	End time

6. DISPLAY

6.1 STANDARD CONDITIONS DISPLAY



At standard conditions the instrument displays
Upper display: temperature and relative measurement unit
Lower display: time and clock symbol.

6.2 DISPLAY DURING A TEMPERATURE ALARM



As soon as the alarm temperature values (max or minimum) are exceeded, the instrument displays.

Upper display: real temperature
Lower display: difference between real temperature and set point, preceded by the "dF" label (difference).

Icons Area:
during the pre-alarm phase (ALd delay): alarm symbols are flashing H_l (high temperature) L_l (low temperature).
At the end of pre-alarm time: alarm symbols are on H_l (high temperature) L_l (low temperature)..

7. ALARM LIST- HACCP MENU

7.1 HOW TO SEE THE ALARMS

- Push the HACCP ▲ key.
- The last alarm happened is showed on the display. The kind of alarm is described by the following codes:
 - Hlt**: High temperature alarm
 - Lot**: Low temperature alarm
 - blou**: black out alarm
 - gEAL**: digital input alarm
- Pushing again the HACCP ▼ key the other alarm are displayed starting from the oldest.
- To see when the alarm happened, its duration and the critical temperature, push the SET key.
- The starting time and date of the alarm are showed alternately, and the Clock and Date icons are turned on, together with the "from" message.
- Pushing again the HACCP ▲ key end time and date of the alarm are showed together with the "to" message.



Push again the HACCP ▲ key, the critical temperature reached is showed together with the time and the date.
The icons of alarm and critical temperature are flashing.



7.2 EXIT

Push the M (menu) key.

8. FUNCTION MENU

It includes all the main functions controlled by the instrument. When it's entered the "menu" message is on.

- **rSt**: to erase all the logged alarms. It can be protected by security code.
- **LOt**: low temperature alarm value. It can be protected by security code.
- **HIt**: high temperature alarm value. It can be protected by security code.
- **ir**: infrared command
- **PASS**: for enabling, modifying and disabling the security code.

8.1 HOW TO ENTER THE FUNCTION MENU



Push and release the M (menu) key.

8.2 HOW TO EXIT THE FUNCTION MENU



Push and release the M (menu) key

8.3 SECURITY CODE INPUT

The functions contained in the Function menu can be protected by security code.

1. If the security code is required the lower display shows "PASS" message while the upper display shows "000" flashing.
2. Use the "UP" key to input the security code in the flashing digit;
3. Confirm the figure by pressing "SET".
4. If the security code is correct the function is enabled, otherwise the security code input process restarts from the beginning.

NOTE: TO EXCLUDE THE SECURITY CODE SET IT TO ZERO.

8.4 rSt FUNCTION: IT ERASES ALL THE LOGGED ALARMS

1. Enter the Function Menu.
2. Select the "rSt" function
3. Push the SET key: if the security code is not required immediately the logged alarm will be erased., otherwise **enter the security code**.
4. If the security code is right the logged alarm are erased and the instrument reverts to room temperature display mode.

8.5 HI T E LOt FUNCTIONS: HOW TO SET THE MAX E MINIMUM TEMPERATURE ALARMS

1. Enter the Function Menu.
2. Select the "LOt" or "HI t" function, then push the SET key.
3. **Enter the security code if required.**
4. Modify the alarm value by means of ▼ or ▲ keys and push the SET key to confirm the new value.

HOW TO SET OR MODIFY THE SECURITY CODE

To change the security code the old security code has to be enter before setting the new one.

1. Enter the Function Menu.
2. Select the "PASS" function on the lower display, the upper display shows the "oLd" message.
3. Push the SET key. If the security code is DISABLED (equal to zero) pass to the point 6.
4. The upper display shows "000" flashing.
5. **Enter the current security code and confirm it by pressing the SET key.**
6. The upper display shows "nEU" message. Push the SET key to enter the function.
7. Use "UP" or "DOWN" to input the security code in the flashing digits;
8. Confirm the figure by pressing "SET".
9. The Upper display will flash for few seconds and the following function will be displayed.

8.6 ir FUNCTION: INFRARED TRANSMISSION

To download the logged alarms from the instrument to the mobile device iPrint act as follow::

1. Enter the Function Menu.
2. Select the "ir" function
3. Push the SET key. The icons will be lighted ant the instruments reverts to temperature displaying.
4. Push the download key on the iPrint device and draw it up to the controller.

9. OTHER FUNCTIONS OF THE KEYBOARD

9.1 HOW TO CHANGE THE SET-POINT



- 1) Push the SET key for more than 2 seconds;
- 2) The value of the set point will be displayed and the LED starts blinking;
- 3) To change the Set value push the ▲ or ▼ within 15s.
- 4) To memorise the new set point value push the SET key again or wait 15s.

9.2 HOW TO START A MANUAL DEFROST



Push the ▲ key for more than 2s

9.3 HOW TO ENTER THE "PR1" PARAMETER LIST



- To change the parameter's value operate as follows:
1. Enter the Programming mode by pressing the Set and DOWN key for 3s (and start blinking).
 2. Select the required parameter. The name of the parameter is on the lower display, its value on the upper.
 3. Press the "SET" key: the value of the parameter will start blinking.
 4. Use "UP" or "DOWN" to change the value.
 5. Press "SET" to store the new value and move to the following parameter.
- To exit:** Press SET + UP or wait 15s without pressing a key.
NOTE: the set value is stored even when the procedure is exited by waiting the time-out to expire.

9.4 TO ENTER IN PARAMETERS LIST "PR2"

- To access parameters in "Pr2":
1. Enter the "Pr1" level.
 2. Select "Pr2" – "PAS" parameter and press the "SET" key.
 3. The flashing value "000" is displayed. If the password is disabled press the SET key, **otherwise** use ▲ or ▼ to input the security code and confirm the figure by pressing "SET" key.

NOTE: each parameter in "Pr2" can be removed or put into "Pr1" (user level) by pressing "SET" + ▼. When a parameter is present also in "Pr1" decimal point of the lower display is on.

9.5 HOW TO CHANGE THE PARAMETER VALUE

1. Enter the Programming mode.
 2. Select the required parameter with ▲ or ▼.
 3. Press the "SET" key the value start blinking.
 4. Use ▲ or ▼ to change its value.
 5. Press "SET" to store the new value and move to the following parameter.
- To exit:** Press SET + UP or wait 15s without pressing a key.
NOTE: the new programming is stored even when the procedure is exited by waiting the time-out.

9.6 HOW TO LOCK THE KEYBOARD



- Keep the ▲ and ▼ keys pressed together for more than 3 s the ▲ and ▼ keys.
2. The "POF" message will be displayed and the keyboard is locked. At this point it is only possible to view the set point or enter the HACCP menu.

9.7 TO UNLOCK THE KEYBOARD

Keep the ▲ and ▼ keys pressed together for more than 3s till the "POn" flashing message appears.

10. CONTROLLING LOADS

10.1 THE COMPRESSOR

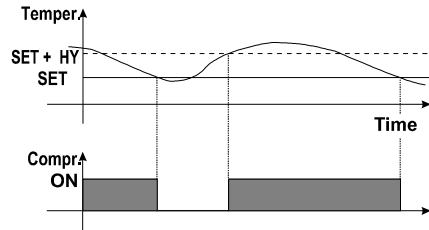

The regulation is performed according to the temperature measured by the thermostat probe with a positive differential from the set point: if the temperature increases and reaches set point plus differential the compressor is started and then turned off when the temperature reaches the set point value again.

In case of fault in the thermostat probe the start and stop of the compressor are timed through parameters "CO_n" and "CO_F".

10.2 DEFROST

XR720C

Defrost is performed through a simple stop of the compressor. Beginning of defrost cycles is set by the Ld1÷Ld8 parameters during the working days and Sd1÷Sd8 during the holidays, while its length is controlled by parameter "MdF".

XR740C, XR760C

Two defrost modes are available through the "tdF" parameter:

- tdF= rE defrost with electrical heater
- tdF= in or hot gas.

The defrost interval is control by means of parameter "EdF":

- rtc: beginning of defrost cycles is set by the Ld1÷Ld8 parameters during the working days and Sd1÷Sd8 during the holidays
- in the defrost is made every "ldF" time
- Sd the interval "ldF" is calculate through Smart Defrost algorithm (only when the compressor is ON)

At the end of defrost the drip time is controlled through the "Fd_t" parameter.

10.3 CONTROL OF EVAPORATOR FANS (ONLY FOR XR760C)

The fan control mode is selected by means of the "FnC" parameter:

- FnC=C-n fans will switch ON and OFF with the compressor and **not run** during defrost;
- FnC= O-n fans will run continuously, but not during defrost

After defrost, there is a timed fan delay allowing for drip time, set by means of the "Fn_d" parameter.

- FnC=C-y fans will switch ON and OFF with the compressor and **run** during defrost;
- FnC=O-y fans will run continuously also during defrost

An additional parameter "FSt" provides the setting of temperature, detected by the evaporator probe, above which the fans are always OFF. This can be used to make sure circulation of air only if his temperature is lower than set in "FSt".

11. PARAMETER LIST

REGULATION

- Hy Differential:** (0,1÷25,5°C; 1÷45°F): Intervention differential for set point, always positive. Compressor Cut IN is Set Point Plus Differential (Hy). Compressor Cut OUT is when the temperature reaches the set point.
- LS Minimum set point limit:** (-50,0°C+SET; -58°F+SET) Sets the minimum acceptable value for the set point.
- US Maximum set point limit:** (SET+110°C; SET÷230°F) Set the maximum acceptable value for set point.
- OdS Outputs activation delay at start up:** (0÷255 min) This function is enabled at the initial start up of the instrument and inhibits any output activation for the period of time set in the parameter. (Light can work)
- AC Anti-short cycle delay:** (0÷30 min) interval between the compressor stop and the following restart.
- Con Compressor ON time with faulty probe:** (0÷255 min) time during which the compressor is active in case of faulty thermostat probe. With CO_n=0 compressor is always OFF.
- COF Compressor OFF time with faulty probe:** (0÷255 min) time during which the compressor is off in case of faulty thermostat probe. With CO_F=0 compressor is always active.
- CH Type of action (only for XR720C):** CL = cooling; Ht = heating.

DISPLAY

- CF Temperature measurement unit:** °C = Celsius; °F = Fahrenheit. When the measurement unit is changed the SET point and the values of some parameters have to be modified.
- rES Resolution (for °C):** (in = 1°C; de = 0,1°C) allows decimal point display.
dE = 0,1°C; in = 1 °C

Lod Local display : select which probe is displayed by the instrument:

- P1 = Thermostat probe
- P2 = Evaporator probe (only for XR740C, XR760C)
- P2 = Third probe

DEFROST

tdF Defrost type (only for XR740C, XR760C):

- rE = electrical heater (Compressor OFF)
- in = hot gas (Compressor and defrost relays ON)

EdF Defrost mode:

- rtc = defrost according to the Ld1÷Ld8 parameters during the working days and Sd1÷Sd8 during the holidays.
- in = interval mode. The defrost starts when the time "ldf" is expired.
- Sd = Smartfrost mode. The time ldF (interval between defrosts) is increased only when the compressor is running (even non consecutively).

SdF Set point for SMARTDEFROST (only for XR740C, XR760C): (-30÷30 °C/ -22÷86 °F) evaporator temperature which allows the ldF counting (interval between defrosts) in SMARTFROST mode.

dTE Defrost termination temperature (only for XR740C, XR760C): (-50,0÷110,0°C; -58÷230°F) (Enabled only when the evaporator probe is present) sets the temperature measured by the evaporator probe which causes the end of defrost.

ldF Interval between defrosts: (1÷120h) Determines the time interval between the beginning of two defrost cycles.

MdF (Maximum) duration of defrost: (0÷255 min) When P2P = no, no evaporator probe, it sets the defrost duration, when P2P = yES, defrost end based on temperature, it sets the maximum length for defrost.

dFd Display during defrost:

- rt = real temperature; it = temperature reading at the defrost start;
- Set = set point; dEF = "dEF" label; dEG = "dEG" label;

dAd Defrost display time out: (0÷255 min) Sets the maximum time between the end of defrost and the restarting of the real room temperature display.

dSd Start defrost delay (only for XR740C, XR760C): (0÷99min) This is useful when different defrost start times are necessary to avoid overloading the plant.

Fdt Drain down time (only for XR740C, XR760C): (0÷60 min.) time interval between reaching defrost termination temperature and the restoring of the control's normal operation. This time allows the evaporator to eliminate water drops that might have formed due to defrost.

dPO First defrost after start-up:

- yES = Immediately; no = after the ldF time

FANS (only for XR760C)

FnC Fan operating mode:

- C-n = running with the compressor, OFF during the defrost;
- C-y = running with the compressor, ON during the defrost;
- O-n = continuous mode, OFF during the defrost;
- O-y = continuous mode, ON during the defrost;

Fn_d Fan delay after defrost: (0÷255 min) The time interval between the defrost end and evaporator fans start.

FSt Fan stop temperature: (-50÷110°C; -58÷230°F) setting of temperature, detected by evaporator probe, above which the fan is always OFF.

ALARMS

AFH Temperature alarm and fan differential: (0,1÷25,5°C; 1÷45°F) Intervention differential for temperature alarm set point and fan regulation set point, always positive.

ALD Temperature alarm delay: (0÷255 min) time interval between the detection of an alarm condition and the corresponding alarm signalling.

dAO Delay of temperature alarm at start-up: (0min÷23h 50min) time interval between the detection of the temperature alarm condition after the instrument power on and the alarm signalling.

EdA Alarm delay at the end of defrost: (0÷255 min) Time interval between the detection of the temperature alarm condition at the end of defrost and the alarm signalling.

dAE Temperature alarm enabling during the defrost:

- no = temperature alarms disable during the defrost;
- YES= temperature alarm enabled during the defrost

doA Open door alarm delay:(0÷255 min) delay between the detection of the open door condition and its alarm signalling: the flashing message "dA" is displayed.

bLE Black out alarm enabling:

- no= black out alarm disabled: at power on the instrument follow the dAo time in alarm signalling; yES= black out alarm enabled: the instrument log possibly black outs.

nPS Pressure switch number: (0 ÷15) Number of activation of the pressure switch, during the "did" interval, before signalling the alarm event (I2F= PAL).

If the nPS activation in the did time is reached, switch off and on the instrument to restart normal regulation. With nPS=0 or 1 the instrument is locked as soon as a the digital input is enabled.

ALP Alarm probe setting:

- P1 = thermostat probe is used for temperature alarms signalling
- P2 = evaporator probe is used for temperature alarms signalling (only for XR740C, XR760C)

P3 = third probe is used for temperature alarms signalling

PROBE INPUTS

- Ot** Thermostat probe calibration: (-12.0+12.0°C / -21+21°F) allows to adjust possible offset of the thermostat probe.
- OE** Evaporator probe calibration (only for XR740C, XR760C): (-12.0+12.0°C / -21+21°F) allows to adjust possible offsets of the evaporator probe.
- O3** Third probe calibration: (-12.0+12.0°C / -21+21°F) allows to adjust possible offsets of the third probe.
- P2P** Evaporator probe presence (only for XR740C, XR760C): no= not present: the defrost stops only by time; yES= present: the defrost stops by temperature and time.
- P3P** Auxiliary probe presence: no= not present; yES= present.
- Pbr** Regulation probe selection: P1 = Thermostat probe; P2 = Evaporator probe (only for XR740C, XR760C); P3 = Auxiliary probe
- HES** Temperature increase during the Energy Saving cycle : (-30+30°C / -54+54°F) sets the increasing value of the set point during the Energy Saving cycle.

DIGITAL INPUTS

- odc** Compressor and fan status when open door:
no = normal; Fan = Fan OFF; CPr = Compressor OFF; F_C = Compressor and fan OFF.
- i2P** Configurable digital input polarity:
CL : the digital input is activated by closing the contact;
OP : the digital input is activated by opening the contact
- i2F** Digital input operating mode: configure the digital input function:
dor = door switch function; EAL = generic alarm;
bAL = serious alarm mode; PAL = Pressure switch;
dFr = Start defrost; AUS = Not used;
Es = Energy Saving; onF = remote On/OFF.
HdF =Holiday function: dor= door switch
- did** Time interval/delay for digital input alarm:(0+255 min.) Time interval to calculate the number of the pressure switch activation when I2F=PAL. If I2F=EAL or bAL (external alarms), "did" parameter defines the time delay between the detection and the successive signalling of the alarm.

REAL TIME CLOCK AND DEFROST CYCLES

- Hur** Current hour (0 ÷ 23 h)
 - Min** Current minute (0 ÷ 59min)
 - dAY** Current day (Sun ÷ SAT)
 - UdA:** day of the week (Sun= Sunday, Mon= Monday, tuE = Thursday, UED = Wednesday, tHu = Thursday, Fri = Friday, SAT =Saturday).
 - dAy:** day of month (0÷31)
 - Mon:** month(1÷12)
 - yEA:** year (00÷99)
 - Hd1** First weekly holiday (Sun ÷ nu) Set the first day of the week which follows the holiday times.
 - Hd2** Second weekly holiday (Sun ÷ nu) Set the second day of the week which follows the holiday times.
 - Hd3** Third weekly holiday (Sun ÷ nu) Set the third day of the week which follows the holiday times.
- N.B. Hd1,Hd2,Hd3 can be set also as "nu" value (Not Used).

TO SET ENERGY SAVING TIMES

- ILE** Energy Saving cycle start during workdays: (0 ÷ 23h 50 min.) During the Energy Saving cycle the set point is increased by the value in HES so that the operation set point is SET + HES.
- dLe** Energy Saving cycle length during workdays: (0 ÷ 24h 00 min.) Sets the duration of the Energy Saving cycle on workdays.
- ISE** Energy Saving cycle start on holidays. (0 ÷ 23h 50 min.)
- dSE** Energy Saving cycle length on holidays (0 ÷ 24h 00 min.)
- HES** Temperature increase during the Energy Saving cycle (-30+30°C / -54+54°F) sets the increasing value of the set point during the Energy Saving cycle.

TO SET DEFROST TIMES

- Ld1÷Ld8** Workday defrost start (0÷23h 50 min.; nu.) These parameters set the beginning of the eight programmable defrost cycles during workdays. Ex. When Ld2 = 12.4 the second defrost starts at 12.40 during workdays.
 - Sd1÷Sd8** Holiday defrost start (0÷23h 50 min.; nu) These parameters set the beginning of the eight programmable defrost cycles on holidays. Ex. When Sd2 = 3.4 the second defrost starts at 3.40 on holidays.
- N.B. : To disable a defrost cycle set it to "nu" (not used).
Ex. If Ld6=nu ; the sixth defrost cycle is disabled

OTHER

- PLA** Language selection for the iPrint device: itA= Italian; enG= English; FrA= France; dEU= German
- dP1** First probe display
- dP2** Second probe display (XR740C, XR760C)

dP3 Third probe display

- Ptb** Parameter table: (read only) it shows the original code of the **dixell** parameter map.
- rEL** Release software: (read only) Software version of the microprocessor.
- Pr2** Access to the protected parameter list (read only).

12. DIGITAL INPUT

The instrument can support 1 free contact digital input. Its functioning is programmable in seven different configurations by the "I2F" parameter.

12.1 DOOR SWITCH INPUT (i2F=dor)

- It signals the door status and the corresponding relay output status through the "odc" parameter:
no = normal (any change);
Fan = Fan OFF;
CPr = Compressor OFF;
F_C = Compressor and fan OFF.

Since the door is opened, after the delay time set through parameter "dOA", the alarm output is enabled and the display shows the message "dA". The alarm stops as soon as the external digital input is disabled again.

12.2 CONFIGURABLE INPUT - GENERIC ALARM (i2F=EAL)

As soon as the digital input is activated the unit will wait for "did" time delay before signalling the "EAL" alarm message. The outputs status don't change. The alarm stops just after the digital input is de-activated.

12.3 CONFIGURABLE INPUT - SERIOUS ALARM MODE (i2F=bAL)

When the digital input is activated, the unit will wait for "did" delay before signalling the "BAL" alarm message. The relay outputs are switched OFF. The alarm will stop as soon as the digital input is de-activated.

12.4 CONFIGURABLE INPUT - PRESSURE SWITCH (i2F=PAL)

If during the interval time set by "did" parameter, the pressure switch has reached the number of activation of the "nPS" parameter, the "PAL" pressure alarm message will be displayed. The compressor and the regulation are stopped. When the digital input is ON the compressor is always OFF. **To restart the normal functioning the controller HAS TO BE SWITCHED OFF and ON AGAIN**

12.5 CONFIGURABLE INPUT - START DEFROST (i2F=dFr)

It executes a defrost if there are the right conditions. After the defrost is finished, the normal regulation will restart only if the digital input is disabled otherwise the instrument will wait until the "Mdf" safety time is expired.

12.6 CONFIGURABLE INPUT - ENERGY SAVING (i2F=ES)

The Energy Saving function allows to change the set point value as the result of the SET+ HES (parameter) sum. This function is enabled until the digital input is activated.

12.7 CONFIGURABLE INPUT - REMOTE ON/OFF (i2F=onF)

This function allows to switch ON and OFF the instrument.

12.8 CONFIGURABLE INPUT - HOLIDAY FUNCTION (i2F=HdF)

In Holiday function Energy saving and defrost cycles follow holiday times. (Sd1...Sd8)

12.9 DIGITAL INPUTS POLARITY

- The digital inputs polarity depends on "i2P" parameter.
CL : the digital input is activated by closing the contact.
OP : the digital input is activated by opening the contact

13. INSTALLATION AND MOUNTING

Instruments shall be mounted on panel, in a 29x71 mm hole, and fixed using the special brackets supplied.

To obtain an IP65 protection grade use the front panel rubber gasket (mod. RG-C) as shown in figure.

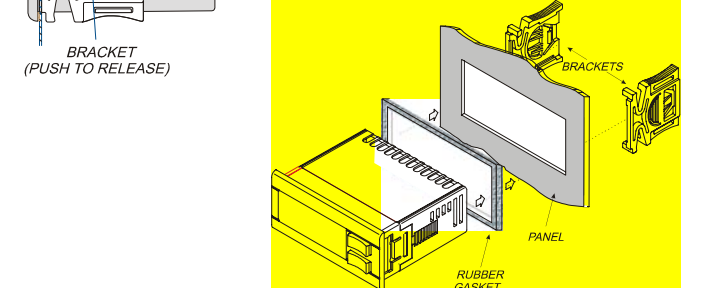

The temperature range allowed for correct operation is 0÷60 °C. Avoid places subject to strong vibrations, corrosive gases, excessive dirt or humidity. The same recommendations apply to probes. Let air circulate by the cooling holes.

14. ELECTRICAL CONNECTIONS

The instrument are provided with screw terminal block to connect cables with a cross section up to 2,5 mm². Heat-resistant cables have to be used. Before connecting cables make sure the power supply complies with the instrument's requirements. Separate the probe cables from the power supply cables, from the outputs and the power connections. Do not exceed the maximum current allowed on each relay, in case of heavier loads use a suitable external relay.

14.1 PROBE CONNECTION

The probes shall be mounted with the bulb upwards to prevent damages due to casual liquid infiltration. It is recommended to place probe away from air streams to correctly measure the average room temperature.

15. USE OF THE PROGRAMMING "HOT KEY"

The unit can UPLOAD or DOWNLOAD the parameter list from its own E2 internal memory to the "Hot Key" and vice-versa.

15.1 DOWNLOAD (FROM THE "HOT KEY" TO THE INSTRUMENT)

1. Turn OFF the instrument, insert the "Hot Key" and then turn the instrument ON.
2. Automatically the parameter list of the "Hot Key" is downloaded into the memory, the "doL" message is blinking. After 10 seconds the instrument will restart working with the new parameters.
3. Turn OFF the instrument remove the "Hot Key", plug in the TTL serial cable, then turn it ON again.

At the end of the data transfer phase the instrument displays the following messages: "end" for right programming. The instrument starts regularly with the new programming. "err" for failed programming. In this case turn the unit off and then on if you want to restart the download again or remove the "Hot key" to abort the operation.

15.2 UPLOAD (FROM THE INSTRUMENT TO THE "HOT KEY")

1. When the unit is ON, insert the "Hot key" and push **ca** key; the "uPL" message appears.
2. Push "SET" key to start the UPLOAD; the "uPL" message is blinking.
3. Turn OFF the instrument remove the "Hot Key", plug in the TTL serial cable, then turn it ON again.

At the end of the data transfer phase the instrument displays the following messages: "end" for right programming. "err" for failed programming. In this case push "SET" key if you want to restart the programming again or remove the not programmed "Hot key".

16. ALARM SIGNALS

Message	Cause	Outputs
"P1"	Thermostat probe failure	Alarm output ON; Compressor output according to parameters "CO _n " and "CO _F "
"P2"	Evaporator probe failure (only for XR740C, XR760C)	Alarm output ON; Other outputs unchanged
"P3"	Auxiliary probe failure	Alarm output ON; Other outputs unchanged
"dA"	Door switch alarm	Alarm output ON; Other outputs unchanged
"EAL"	External alarm	Alarm output ON; Other outputs unchanged
"bAL"	Serious external alarm	Alarm output ON; Other outputs OFF
"PAL"	Pressure switch alarm	Alarm output ON; Other outputs OFF
"rtc"	Real time clock alarm	Alarm output ON; Other outputs unchanged; Defrosts according to par. "IdF"

The alarm message is displayed until the alarm condition is recovery. All the alarm messages are showed alternating with the room temperature except for the "P1" which is flashing.

16.1 SILENCING BUZZER

Once the alarm signal is detected the buzzer is silenced by pressing any key.

16.2 ALARM RECOVERY

Probe alarms : "P1" (probe1 faulty), "P2" and "P3"; they automatically stop 10s after the probe restarts normal operation. Check connections before replacing the probe.
 Door switch alarm "dA" stop as soon as the door is closed.
 External alarms "EAL", "BAL" stop as soon as the external digital input is disabled
 "PAL" alarm is recovered by switching OFF the instrument.

17. TECHNICAL DATA

Housing: self extinguishing ABS.
Case: frontal 32x74 mm; depth 60mm;
Mounting: panel mounting in a 71x29mm panel cut-out
Protection: IP20.

Frontal protection: IP65 with frontal gasket RG-C (optional).
Connections: Screw terminal block ≤ 2,5 mm² heat-resistant wiring.
Power supply: 230Vac (opt.110Vac), ±10%
Power absorption: 3VA max.
Inputs: 3 NTC probes
Relay outputs
 compressor: SPST relay 8(3) A, 250Vac or
 defrost: relay SPDT 8(3) A, 250Vac (XR740C, XR760C)
 fans: relay SPST 8(3) A, 250Vac (XR760C)
Other output: Alarm buzzer
Kind of action: 1B.
Pollution grade: normal
Software class: A.
Data storing: on the non-volatile memory (EEPROM).
Operating temperature: 0÷60 °C.
Storage temperature: -25÷60 °C.
Relative humidity: 20÷85% (no condensing)
Measuring and regulation range: -40÷110 °C (-58÷230°F)
Resolution: 0,1 °C or 1°C or 1 °F (selectable).
Accuracy (ambient temp. 25°C): range -40÷50°C (-40÷122°F): ±0,5 °C ±1 digit

18. WIRING CONNECTIONS

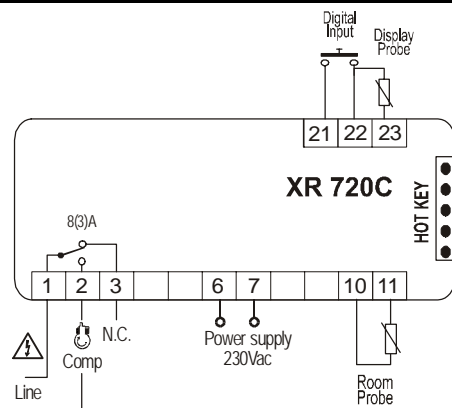

Power supply 115Vac: connect to 6-7 terminals

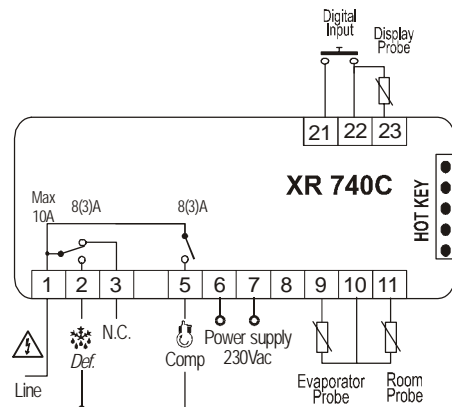

Power supply 115Vac: connect to 6-7 terminals

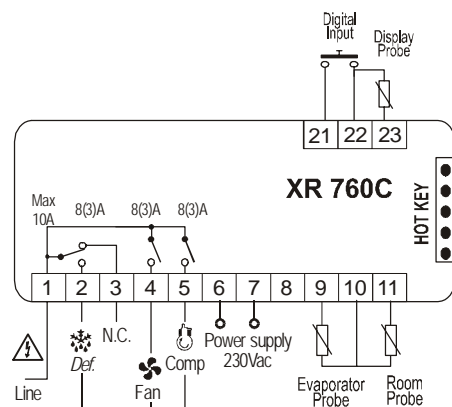

Power supply 115Vac: connect to 6-7 terminals

19. CONNECT TO 6-7 TERMINALS DEFAULT SETTING VALUES

19.1 FUNCTION MENU

Label	Meaning	Range	XR720C	XR740C	XR760C
Lot	Low temperature alarm	-40°C÷Hit	-10.0	-10.0	-10.0
Hit	High temperature alarm	Lot ÷110°C	10.0	10.0	10.0
PASS	Security code	0÷999	0	0	0

19.2 PARAMETER LIST

Par.	Meaning	Range	XR720C		XR740C		XR760C	
REGULATION								
Set	Set point	LS÷US	3.0	Pr1	-5.0	Pr1	-5.0	Pr1
Hy	Differential	0,1÷25,5 °C / 1÷45°F	2.0	Pr1	2.0	Pr1	2.0	Pr1
LS	Minimum set point	-50,0°C÷SET / -58°F÷SET	-10.0	Pr2	-30.0	Pr2	-30.0	Pr2
US	Maximum set point	SET ÷ 110°C / SET ÷ 230°F	20.0	Pr2	20.0	Pr2	20.0	Pr2
OdS	Outputs activation delay at start up	0÷255 min.	0	Pr2	0	Pr2	0	Pr2
AC	Anti-short cycle delay	0÷30 min.	1	Pr1	1	Pr1	1	Pr1
CO _n	Compressor ON time with faulty probe	0÷255 min.	15	Pr2	15	Pr2	15	Pr2
COF	Compressor OFF time with faulty probe	0÷255 min.	30	Pr2	30	Pr2	30	Pr2
CH	Kind of action	CL=cooling; Ht=Heating	cL	Pr2	-	-	-	-
DISPLAY								
CF	Temperature measurement unit	°C ÷ °F	°C	Pr2	°C	Pr2	°C	Pr2
rES	Resolution (integer/decimal point)	in ÷ de	dE	Pr1	dE	Pr1	dE	Pr1
Lod	Local display	P1, P2, P3	P1	Pr2	P1	Pr2	P1	Pr2
DEFROST								
tdF	Defrost type	rE, in	-	-	rE	Pr1	rE	Pr1
EdF	Defrost mode	rtc, In, Sd	rtc	Pr2	RTC	Pr2	RTC	Pr2
SdF	Set point for SMART DEFROST	-30 ÷ +30°C / -22÷+86°F	-	-	0	Pr2	0	Pr2
dtE	Defrost termination temperature (1°Evaporator)	-50,0÷110°C / -58÷230°F	-	-	8.0	Pr1	8.0	Pr1
ldF	Interval between defrost cycles	1÷120h	8	Pr1	6	Pr1	6	Pr1
MdF	(Maximum) length for 1° defrost	0÷255 min.	20	Pr1	30	Pr1	30	Pr1
dFd	Displaying during defrost	rt, it, SEt, dEF, dEG	it	Pr2	it	Pr2	it	Pr2
dAd	MAX display delay after defrost	0÷255 min.	30	Pr2	30	Pr2	30	Pr2
dSd	Defrost delay after calling	0÷255 min	-	-	0	Pr2	0	Pr2
Fdt	Draining time	0÷60 min.	-	-	0	Pr2	0	Pr2
dPO	First defrost after start up	no ÷ yES	no	Pr2	no	Pr2	no	Pr2
FANS								
FnC	Fans operating mode	C-n, C-y, O-n, O-y	-	-	-	-	O-n	Pr2
Fnd	Fans delay after defrost	0÷255 min.	-	-	-	-	10	Pr2
FSt	Fans stop temperature	-50,0÷110°C / -58÷230°F	-	-	-	-	2,0	Pr2
ALARMS								
AFH	Temperature alarm and fan differential	0,1÷25,5 °C / 1÷45°F	2.0	Pr2	2.0	Pr2	2.0	Pr2
ALd	Temperature alarm delay	0÷255 min.	15	Pr2	15	Pr2	15	Pr2
dAO	Delay of temperature alarm at start up	0 ÷ 23h 50 min.	1.3	Pr2	1.3	Pr2	1.3	Pr2
EdA	Alarm delay at the end of defrost	0÷255 min.	30	Pr2	30	Pr2	30	Pr2
dAE	Temperat. alarm enabled during defrost	yES ÷ no	no	Pr2	no	Pr2	no	Pr2
dOA	Open door alarm delay	0÷254 min.,nu	15	Pr2	15	Pr2	15	Pr2
bLE	Black out alarms enabling	yES ÷ no	yES	Pr2	yES	Pr2	yES	Pr2
nPS	Pressure switch activation number	0÷15	0	Pr2	0	Pr2	0	Pr2
ALP	Alarm probe selection	P1, P2, P3	P1	Pr2	P1	Pr2	P1	Pr2
ANALOGUE INPUTS								
Ot	Thermostat probe calibration	-12,0÷12,0°C / -21÷21°F	0.0	Pr2	0.0	Pr1	0.0	Pr1
OE	Evaporator probe calibration	-12,0÷12,0°C / -21÷21°F	-	-	0.0	Pr2	0.0	Pr2
O3	Auxiliary probe calibration	-12,0÷12,0°C / -21÷21°F	0.0	Pr2	0.0	Pr2	0.0	Pr2
P2P	Evaporator probe presence	no ÷ yES	-	-	yES	Pr2	yES	Pr2
P3P	Auxiliary probe presence	no ÷ yES	no	Pr2	no	Pr2	no	Pr2
Pbr	Regulation probe	P1, P2, P3	P1	Pr2	P1	Pr2	P1	Pr2
HES	Temperature increase during the Energy Saving cycle	-30÷30°C / -54÷54°F	0	Pr2	0	Pr2	0	Pr2
DIGITAL INPUTS								
Odc	Open door control	no, Fan, CP _r , F_C	no	Pr2	no	Pr2	FAn	Pr2
i2P	Configurable digital input polarity	CL÷OP	cL	Pr2	cL	Pr2	cL	Pr2
i2F	Digital input configuration	EAL, bAL, PAL, dFr, AUS, ES, OnF; dor	dor	Pr2	dor	Pr2	dor	Pr2
dlid	Digital input alarm delay	0÷255 min.	5	Pr2	5	Pr2	5	Pr2
TIME AND WEEKLY HOLIDAYS								
Hur	Current hour	0 ÷ 23	-	rtc	-	rtc	-	rtc
Min	Current minute	0 ÷ 59	-	rtc	-	rtc	-	rtc
UdA	Current day of the week	Sun) ÷ SA _t	-	rtc	-	rtc	-	rtc
dAY	Current day	1 ÷ 31	-	rtc	-	rtc	-	rtc
MO _n	Month	1 ÷ 12	-	rtc	-	rtc	-	rtc

Par.	Meaning	Range	XR720C		XR740C		XR760C	
YEA	Year	0 ÷ 99	-	rtc	-	rtc	-	rtc
Hd1	First weekly holiday	Sun÷ SAT – nu	nu	rtc	nu	rtc	nu	rtc
Hd2	Second weekly holiday	Sun÷ SAT – nu	nu	rtc	nu	rtc	nu	rtc
Hd3	Third weekly holiday	Sun÷ SAT – nu	nu	rtc	nu	rtc	nu	rtc
ENERGY SAVING TIMES								
ILE	Energy Saving cycle start during workdays	0 ÷ 23h 50 min.	0.0	rtc	0.0	Pr2	0.0	Pr2
dLE	Energy Saving cycle length during workdays	0 ÷ 24h 00 min.	0.0	rtc	0.0	Pr2	0.0	Pr2
ISE	Energy Saving cycle start on holidays	0 ÷ 23h 50 min.	0.0	rtc	0.0	Pr2	0.0	Pr2
dSE	Energy Saving cycle length on holidays	0 ÷ 24h 00 min.	0.0	rtc	0.0	Pr2	0.0	Pr2
HES	Temperature increase during the Energy Saving cycle	-30÷30°C / -54÷54°F	0	rtc	0	Pr2	0	Pr2
DEFROST TIMES								
Ld1	1 st workdays defrost start	0 ÷ 23h 50 min. - nu	6.0	rtc	6.0	Pr2	6.0	Pr2
Ld2	2 nd workdays defrost start	0 ÷ 23h 50 min. - nu	13.0	rtc	13.0	Pr2	13.0	Pr2
Ld3	3 rd workdays defrost start	0 ÷ 23h 50 min. - nu	21.0	rtc	21.0	Pr2	21.0	Pr2
Ld4	4 th workdays defrost start	0 ÷ 23h 50 min. - nu	nu	rtc	nu	Pr2	nu	Pr2
Ld5	5 th workdays defrost start	0 ÷ 23h 50 min. - nu	nu	rtc	nu	Pr2	nu	Pr2
Ld6	6 th workdays defrost start	0 ÷ 23h 50 min. - nu	nu	rtc	nu	Pr2	nu	Pr2
Ld7	7 th workdays defrost start	0 ÷ 23h 50 min. - nu	nu	rtc	nu	Pr2	nu	Pr2
Ld8	8 th workdays defrost start	0 ÷ 23h 50 min. - nu	nu	rtc	nu	Pr2	nu	Pr2
Sd1	1 st holiday defrost start	0 ÷ 23h 50 min. - nu	6.0	rtc	6.0	Pr2	6.0	Pr2
Sd2	2 nd holiday defrost start	0 ÷ 23h 50 min. - nu	13.0	rtc	13.0	Pr2	13.0	Pr2
Sd3	3 rd holiday defrost start	0 ÷ 23h 50 min. - nu	21.0	rtc	21.0	Pr2	21.0	Pr2
Sd4	4 th holiday defrost start	0 ÷ 23h 50 min. - nu	nu	rtc	nu	Pr2	nu	Pr2
Sd5	5 th holiday defrost start	0 ÷ 23h 50 min. - nu	nu	rtc	nu	Pr2	nu	Pr2
Sd6	6 th holiday defrost start	0 ÷ 23h 50 min. - nu	nu	rtc	nu	Pr2	nu	Pr2
Sd7	7 th holiday defrost start	0 ÷ 23h 50 min. - nu	nu	rtc	nu	Pr2	nu	Pr2
Sd8	8 th holiday defrost start	0 ÷ 23h 50 min. - nu	nu	rtc	nu	Pr2	nu	Pr2
Other								
PLA	Language selection for iPrint	ITA=Italian; ENG=English; FRA= France; dEU=German	ItA	Pr2	ItA	Pr2	ItA	Pr2
dP1	Room probe readout	---	---	Pr1	---	Pr2	---	Pr2
dP2	Evaporator probe readout	---	-	-	---	Pr2	---	Pr2
dP3	Third probe readout	---	---	Pr1	---	Pr2	---	Pr2
Ptb	Map code	---	---	Pr2	---	Pr2	---	Pr2
rEL	Software release	---	---	Pr2	---	Pr2	---	Pr2
Pr2	Access parameter list		---	Pr1	---	Pr1	---	Pr1

Dixell (Asia) Co., Ltd.

207/71-72 Moo 6 Pattanakarn 61, Pattanakarn Rd,
Praves Bangkok 10250

Tel. (66) 0-2321-3078, 2722-0245 Fax. (66) 0-2320-2520

e-mail: suthiporn@dixellasia.com <http://www.dixellasia.com>